

**PROJECTA**

INTELLI-CHARGE LITHIUM  
**BATTERY CHARGER**

12 VOLT, 5 STAGE SWITCHMODE



P/No IC1500L

## **IMPORTANT SAFETY INFORMATION**

Please read this manual thoroughly before use and store in a safe place for future reference.

### **WARNING**

- Explosive gases may escape from the battery during charging. Prevent flames and sparks. Provide adequate ventilation.
- Before charging, read the instructions.
- For indoor use. Do not expose to rain.
- For charging Lithium Iron Phosphate batteries ONLY.
- Disconnect the 240V mains supply before making or breaking the connections to the battery.
- The battery charger must be plugged into an earthed socket-outlet.
- Connection to supply mains is to be in accordance with National wiring rules.
- Do not attempt to charge non-rechargeable batteries.
- Never charge a frozen battery.
- If the AC cord is damaged do not attempt to use. It must be replaced or repaired by a qualified person.
- Corrosive substances may escape from the battery during charging and damage delicate surfaces. Store and charge in a suitable area.
- Ensure all vehicle accessories including lights, heaters, appliances etc are turned off prior to charging.
- This charger is not intended for use by persons (including children) with reduced physical, sensory or mental capabilities, or lack of experience and knowledge, unless they have been given supervision or instruction concerning use of the appliance by a person responsible for their safety.
- Young children should be supervised to ensure that they do not play with the appliance.

# FEATURES

## 5 STAGE AUTOMATIC CHARGING

This is a fully automatic battery charger with 5 charge stages.

Automatic charging protects your battery from being overcharged so you can leave the charger connected to the battery indefinitely.

5 stage charging is a very comprehensive and accurate charging technique that gives your battery longer life and better performance compared to using traditional chargers.

The 5 charge stages are:

Soft Start 1, Soft Start 2, Bulk, Absorption and Float.

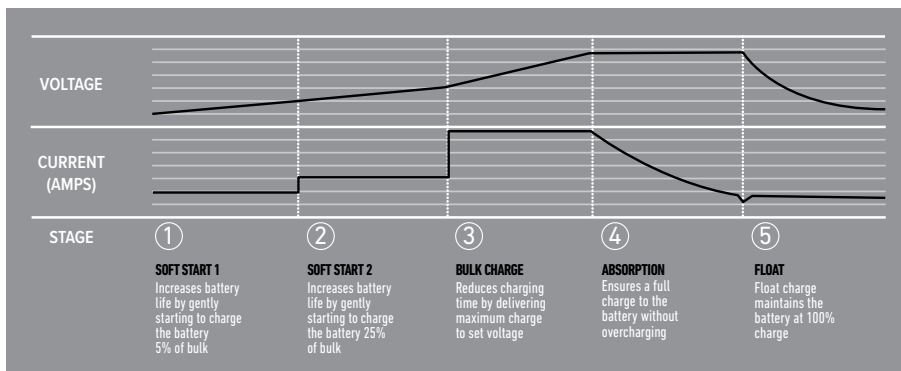

### Soft Start 1

This is a preliminary charge that is for heavily discharged batteries where the voltage is between 2-8 Volts. Charge is limited to 5% of set current.

### Soft Start 2

This is a preliminary charge that is for discharged batteries where the voltage is between 8-10 Volts. Charge is limited to 25% of set current.

### Bulk (Constant Current)

The Bulk stage reduces charging time by charging the battery at the maximum rate (constant current) to a set voltage, at which point the battery is approximately 80% charged.

### Absorption (Constant Voltage)

The absorption stage charges the battery to 100% by adjusting the charge rate allowing the battery to absorb more power.

### Float

The Float stage maintains the battery at 100% charge without overcharging or damaging the battery. This means the charger can be left connected to the battery indefinitely.

## ADJUSTABLE CHARGE RATE

The charger's output can be adjusted to suit the size of the battery for optimum charging.

## POWER SUPPLY

When Power Supply mode is selected, you can safely run an appliance or load from your battery. An appliance can also be run directly from the battery clamps if required, for example using the charger as a memory saver when disconnecting the battery from the vehicle.

## CHARGE STATUS INDICATOR

The CHARGING and FULLY CHARGED LEDs will illuminate and flash in various patterns to indicate the different stages of charging. See below for flash patterns.

		Soft Start 1	Soft Start 2	Bulk	Absorption/	Float
Blue LED	● Charging	----- (Fast Flash)	— — — — (Slow Flash)	—————	—————	
Green LED	● Full				— — — — (Slow Flash)	—————
Red LED	● Power	Solid On: Normal Flashing: Fault (See Faults & Errors, page 13)				

CHARGING LED: blue LED illuminates and flashes during charging process.

FULLY CHARGED LED: green LED illuminates (solid) when fully charged.

## POLARITY PROTECTION

Prevents the output leads from sparking due to accidental reverse connection or short circuit making the charger safer to use around batteries.

## OVER TEMPERATURE PROTECTION

If the temperature within the charger rises too high, the charger will begin to cool down by turning on the fan, and if the temperature continues to rise it will begin reducing the power output. If still unsuccessful, the charger will shutdown until it cools down.

## SWITCHMODE TECHNOLOGY

Using the latest technology in battery chargers, switchmode chargers convert 240VAC power to 12VDC power using electronic components unlike traditional battery chargers that rely on heavy transformers. This allows the charger to be lightweight and compact without sacrificing on performance.

## **COOLING FAN**

The charger is fitted with a thermostatically controlled fan to cool onboard electronics and maintain charging performance. The cooling fan will engage automatically when there is a high load on the battery or there is sufficient heat build up.

## **REMOTE CONTROL DISPLAY\***

Control and monitor the charger's performance from a remote control display, allowing the charger to be flush or surface mounted out of the way and out of sight. The battery charger and remote are synchronised for operation either locally or by remote.

\* Available as a optional extra, not supplied with unit but can be purchased separately (P/No. ICLREMOTE)

## **TEMPERATURE COMPENSATION**

Decreases the charge voltage whilst charging during warmer weather and decreases the charger current when the battery temperature is below 0 deg C, to protect the battery and extend its life.

# SPECIFICATIONS

P/No.	IC1500L
Type	5 stage
Input (Nominal)	240VAC, 50Hz
Input Power	240W
Output Voltage	12V
Output Current	2, 4, 8, 15A
Minimum Start Voltage	2.0V
Back Drain	1mA (2mA with remote)
<b>CHARGE CONTROL</b>	
Soft Start 1	Charge at 5% of set current, until the battery reaches 8.0V
Soft Start 2	Charge at 25% of set current, until the battery reaches 10.0V
Bulk	Set current up to 14.5V
Absorption	Constant voltage of 14.5V until current drops to the following set points: 2 Amp – 0.2A 4 Amp – 0.4A 8 Amp – 0.8A 15 Amp – 1.5A
Float	13.5V
<b>POWER SUPPLY</b>	
Set Voltage	13.8V
Maximum Current	15A
<b>BATTERY RANGE</b>	
Deep Cycle	4–150Ah
Types of Batteries	Lithium Iron Phosphate
Size (mm)	222 x 61 x 108
Weight	1.54 kg

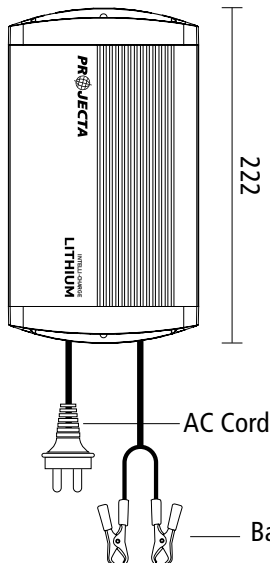
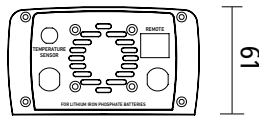
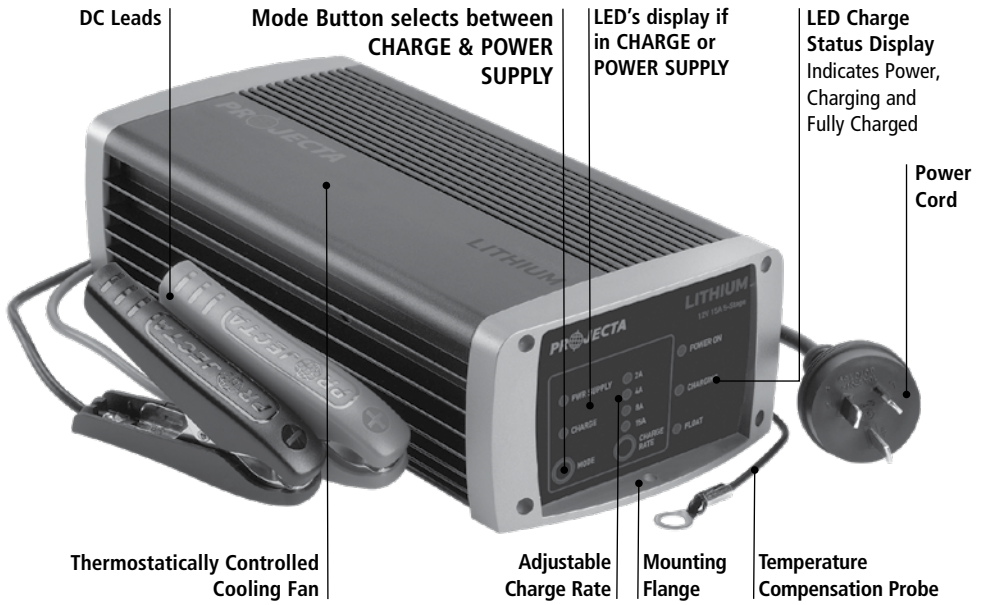

# CHARGING INSTRUCTIONS

## STEP 1A – CONNECTION OUT OF THE VEHICLE

Connect the RED lead (battery clip) from the charger to the Positive (+) battery post.

Connect the BLACK lead (battery clip) from the charger to the Negative (-) battery post.

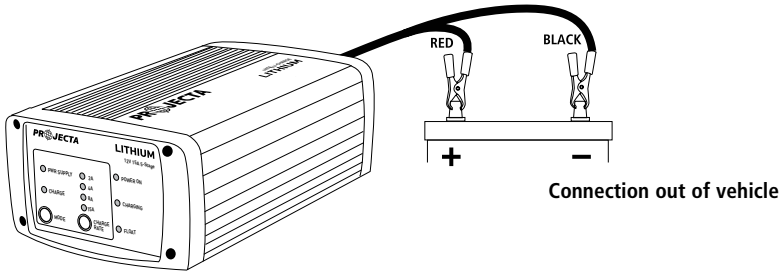

## STEP 1B – CONNECTION IN VEHICLE

Determine if the vehicle is Positively (+) or Negatively (-) earthed. Negatively earthed vehicles have a cable (usually black) from the Negative battery terminal to the vehicle's chassis.

### Negatively earthed (most vehicles)

Connect the RED lead (battery clip) from the charger to the Positive (+) battery terminal.

Connect the BLACK lead (battery clip) from the charger to the vehicle's chassis away from the fuel line or moving parts.

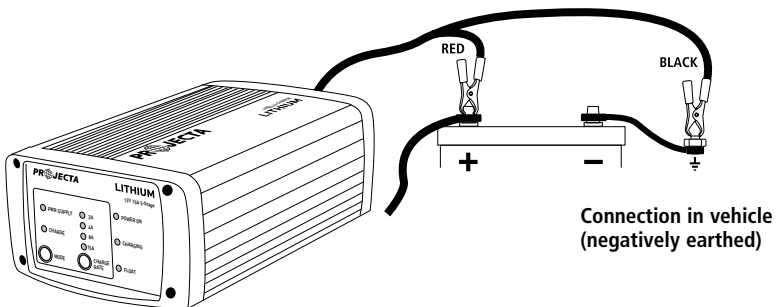



### Positively earthed

Connect the BLACK lead (battery clip) from the charger to the Negative (-) battery terminal.

Connect the RED lead (battery clip) from the charger to the vehicle's chassis away from the fuel line or moving parts.

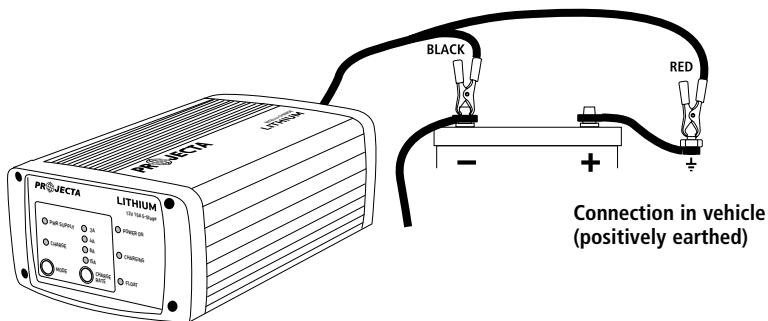

### STEP 2 – REMOTE CONTROL (OPTIONAL) & TEMPERATURE SENSOR

Connect the temperature sensor prior to turning on the charger this is required for lithium charging to maximize life and performance of the battery. If you require the remote control this is optional and must be fitted prior to turning on the power.

To install the remote, insert the data plug into the data socket at the rear of the battery charger.

Cable length: 4.5 metres.

**Warning:** Ensure the cable is secured safely away from moving parts.

#### Installing Temperature Sensor

To install the temperature sensor, insert the plug into the temperature sensor socket at the rear of the battery charger. Install the ring terminal to the negative battery terminal.

Cable length: 1.8 metres.

**Warning:** Ensure the cable is secured safely away from moving parts.

### STEP 3 – CONNECT TO 240V MAINS POWER

Connect the battery charger to the 240V mains powered socket and turn on the mains power.

### STEP 4 – SET CHARGE RATE

The charge rate should be set according to the size of the battery. See the recommended charge rates for various battery sizes in the table on the following page.

- Press the CHARGE RATE or MODE button to enter setting mode.
- Press the CHARGE RATE button until the desired setting is achieved.

## ADJUSTABLE CHARGE RATES: 12 VOLT BATTERIES

Current setting	AH		Time
	C-2	C-10	
2A	4	20	2 – 10h
4A	8	40	2 – 10h
8A	16	80	2 – 10h
15A	30	150	2 – 10h

### STEP 5 – CHARGING

During the charge process, the CHARGING and FULLY CHARGED LED will flash various patterns. This is normal and indicates the various charge stages. Refer to “How can I tell what stage the battery charger is in” in the FAQ section, page 14.

When the FULLY CHARGED LED remains on, this is known as the float stage and the charger can be left connected to the battery without over charging.

If the POWER LED is flashing, there is a fault; refer to “Fault Codes” explanation on page 13 of this manual.

### STEP 6 – DISCONNECTION

Ensure the 240V mains switch is turned off and the charger is disconnected from the 240V mains power.

#### Battery out of vehicle

Remove the BLACK lead (battery clip) from the battery.

Remove the RED lead (battery clip) from battery.

#### Battery in vehicle

Remove the chassis connection.

Remove the battery terminal connection.

## MOUNTING INSTRUCTIONS

INTELLI-CHARGE Chargers are designed for indoor, out of weather use only. Ensure that both charger and battery are in a well-ventilated space during charging.

The battery charger end plates include a mounting flange for easy mounting. If permanently fixed the charger should be mounted to a suitable horizontal or vertical panel, with at least 10cm clearance from the end plates to provide adequate ventilation for the cooling fan.

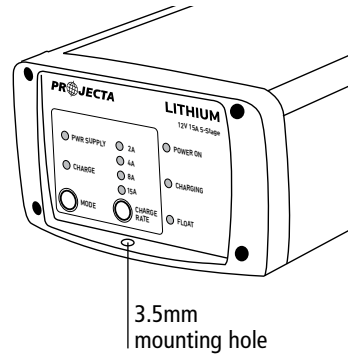

## PERMANENT WIRING TO BATTERY

It is possible to hard wire the DC charging leads to the battery for permanent installations.

You will need 2 x ring terminals, an inline fuse holder and a fuse with a rating equal to or greater than twice the chargers output. (See below)

IC1500L = 30 Amp fuse

Connection:

1. Cut off the supplied battery clips; ensure you leave sufficient cable to reach the battery terminals. (DO NOT extend the battery charger DC cables, as the added voltage drop will cause incorrect charging).
2. Fit a ring terminal to the BLACK Negative (-) wire.
3. Connect the inline fuse to the RED Positive (+) wire.
4. Connect a ring terminal to the other end of the inline fuse.
5. Connect the RED lead (with inline fuse and ring terminal) to the Positive (+) battery post.
6. Connect the BLACK lead (with ring terminal) to the Negative (-) battery post.

7. Fit the correctly rated fuse.

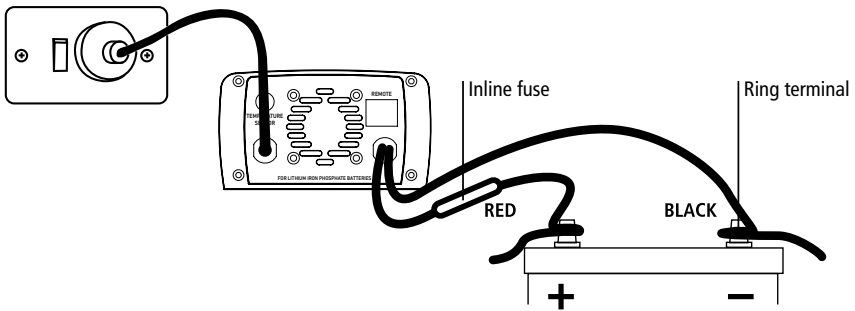

If the charger is used in a Permanent/Hard Wired application and the vehicle will not be used for some time, it is best to leave the charger connected to mains power (turned 'On') so that it can maintain the battery fully charged.

Ensure any modification to the 240V mains lead is carried out by a qualified person and that connection to supply mains is in accordance with National wiring rules.

### **POWER SUPPLY (CONSTANT VOLTAGE OF 13.8 VOLTS)**

This places the charger in Power Supply mode, giving a constant voltage of 13.8VDC. Activated by pressing the 'MODE' key, Power Supply is best used where appliances are drawing power from the battery, for example a fridge. Although the charger is designed to work with a battery connected, it can also function in this way without a battery.

## **LOCKING THE BATTERY CHARGER SETTINGS**

Locking the battery charger settings will disable the CHARGE RATE & MODE keys from use. This function is ideal for hire vehicles etc as it prevents the chargers settings from being altered if the keys are touched.

To lock; press and hold the 'CHARGE RATE' and 'MODE' keys for 3 seconds until all the LEDs illuminate. This indicates the keys are now locked.

To unlock; press and hold and 'CHARGE RATE' and 'MODE' keys for 3 seconds until all the LEDs illuminate. This indicates the keys are now unlocked.

If you have the ICLREMOTE: Lock the screen by pressing and holding the Charge Rate and Charge buttons for 3 seconds.

# FAULT CODES

Error Codes may appear and these are:

Remote LCD	Power (Red LED)	Charging (Blue LED)	Full (Green LED)	Fault	Remedy
Err	— — — (Slow Flash)	OFF	OFF	Short circuit or reverse connection of the clips.	Check clips are not touching each other OR Check the clips are correctly connected to the battery.
F01	----- (Fast Flash)	OFF	ON	Bulk charging has timed out and stopped after 10 hours.	Battery may be faulty.
F02	----- (Fast Flash)	----- (Fast Flash)	OFF	Soft Start has timed out as the battery has not reached 10.0V after 2 hours.	Battery may be faulty, check the battery or try and charge again.
F03	----- (Fast Flash)	OFF	----- (Fast Flash)	Absorption has been charging for more than 20 hours and is now in float mode.	Battery may be faulty or there could be a load on the battery.
CLd				Battery Temp is less than 0°C. Charging at reduced current. To protect the battery.	Warm the battery up.
HtC				Battery Temp is greater than 45°C the charger voltage is reducing, to protect the battery.	Cool the battery down.
OTP	----- (Fast Flash)			The charger has overheated (>70°C) and has switched off.	Ensure adequate ventilation around the charger.
OCP	----- (Fast Flash)			The charger has encountered an error in power supply mode.	Check loads in Power Supply mode.

# FREQUENTLY ASKED QUESTIONS

## Q. How do I know if the battery is charged?

A. The charger's FULLY CHARGED LED will illuminate (solid).

## Q. I have connected the charger properly but the 'CHARGING LED' does not come on?

A. In some cases batteries can be flattened to the point where they have very little or no voltage. This can occur if a small amount of power is used for a long time, for example a map reading light is left on for a week or more. Projecta 5 Stage chargers are designed to charge from as little as 2V.

If the voltage is less than 2.0V this is very low and the battery may not be rechargeable. You could try an electronic powersupply to gradually bring the battery voltage above 2.0V so the charger can then take over or take the battery back to the place of purchase so they can try and repair it.

## Q. Can I use the charger as a power supply

A. Yes, by selecting Power Supply mode you are able to use the charger as a power supply to run an appliance. Ensure the appliance being run is not greater than the charger's output current and where possible connect the charger to a battery, and the battery to the appliance.

The charger may also be used to connect to a vehicle while changing the battery to maintain the vehicles computer and radio settings.

## Q. Why does the charger reset when I connect a load directly to the battery charger in Power Supply mode.

A. The charger will reset when in Power Supply mode if the load exceeds the chargers capacity. Some appliances when turned on or first connected to the charger will cause the charger to reset and it will re-try by slowly ramping up its output.

## Q. How can I tell what stage the battery charger is in?

A. Below are the conditions that are displayed by the LEDs for each of the charge stages.

		Soft Start 1	Soft Start 2	Bulk	Absorption/	Float
Blue LED	● Charging	----- (Fast Flash)	----- (Slow Flash)	_____	_____	
Green LED	● Full				----- (Slow Flash)	_____
Red LED	● Power	Solid On: Normal Flashing: Fault (See Faults & Errors, page 13)				

**Q. What if I have an appliance connected to the battery whilst charging?**

A. Powering an appliance while charging your battery will impact on the battery charger's ability to accurately measure the battery's response to the charge being applied. The battery charger has been designed to accommodate this situation although not recommended.

For optimum charging it is recommended to charge without any appliance load on the battery. Power Supply mode is recommended when an appliance is connected to a battery and is drawing power.

# **WARRANTY STATEMENT**

## **Applicable only to product sold in Australia**

Brown & Watson International Pty Ltd of 1500 Ferntree Gully Road, Knoxfield, Vic., telephone (03) 9730 6000, fax (03) 9730 6050, warrants that all products described in its current catalogue (save and except for all bulbs and lenses whether made of glass or some other substance) will under normal use and service be free of failures in material and workmanship for a period of one (1) year (unless this period has been extended as indicated elsewhere) from the date of the original purchase by the consumer as marked on the invoice. This warranty does not cover ordinary wear and tear, abuse, alteration of products or damage caused by the consumer.

To make a warranty claim the consumer must deliver the product at their cost to the original place of purchase or to any other place which may be nominated by either BWI or the retailer from where the product was bought in order that a warranty assessment may be performed. The consumer must also deliver the original invoice evidencing the date and place of purchase together with an explanation in writing as to the nature of the claim.

In the event that the claim is determined to be for a minor failure of the product then BWI reserves the right to repair or replace it at its discretion. In the event that a major failure is determined the consumer will be entitled to a replacement or a refund as well as compensation for any other reasonably foreseeable loss or damage.

This warranty is in addition to any other rights or remedies that the consumer may have under State or Federal legislation.

## **IMPORTANT NOTE**

Our goods come with guarantees that cannot be excluded under the Australian Consumer Law. You are entitled to a replacement or refund for a major failure and compensation for any other reasonably foreseeable loss or damage. You are also entitled to have the goods repaired or replaced if the goods fail to be of acceptable quality and the failure does not amount to a major failure.

## **Distributed by**

### **AUSTRALIA**

**Brown & Watson International Pty Ltd**

Knoxfield, Victoria 3180

Telephone (03) 9730 6000

Facsimile (03) 9730 6050

National Toll Free 1800 113 443

### **NEW ZEALAND**

**Narva New Zealand Ltd**

22–24 Olive Road

PO Box 12556 Penrose

Auckland, New Zealand

Telephone (09) 525 4575

Facsimile (09) 579 1192